



BUTTON EXTENSION RELEASE
TYPE FD3050G
INSTRUCTION MANUAL 01-3050G

GENERAL DESCRIPTION

Button EXTENSION RELEASE is designed for individual operation. It can be used to activate additional (independent) automatics, performing extinguishing from additional source of extinguishing agent. Install the button on appropriate place, convenient for the user.

The button has a built-in switcher with one normally open contact and resistor of 1,5 kΩ. When pressing the button, the contact is closed and commutates circuit through resistor of 1,5 kΩ.

FD3050 G consists of : surface mounting back box (pos.4, fig.1), a carrier unit (pos.3, fig.1), a glass element with protective sticker (pos.5, fig.1), a test key (pos.6, fig.1), a breakable seal (pos.7, fig.1), a cover (pos.2, fig.1) and a protective cover (pos.1, fig.1).

To activate the EXTENSION RELEASE Button:

1. Open the protective cover, fixed by means of the breakable seal.
2. Break the glass element on the place, designated by the arrows. The button is activated.

To enable the button EXTENSION RELEASE Button:

1. Dismantle the cover (pos.2, fig.1) and replace the glass element, (pos.5, fig.1) and the torn breakable seal (pos.7, fig.1).
2. Mount the cover by the reverse order and fix the protective cover by means of the breakable seal.
3. The button is ready for new activation.

TECHNICAL DATA

Button	one normally open contact
Electrical installation	by means of terminal for installation wires with cross section (0,8-1,5) mm ²
Degree of protection	IP 40
Operating temperature range	from minus 10°C to plus 60°C
Relative humidity resistance	(93±3)% at 40°C
Dimensions	90 x 90 x 44 mm (90 x 90 x 56 - extended back box for surface mounting)
Material	ABS, green

INSTALLATION

To install the button, please observe the following sequence:

1. Dismantle the basic components of the unit, shown on fig.1 by unscrewing the fixings.
2. Fix the back box on the wall by means of dowels and self-tapping screws.
3. Join the wires of the input line to terminals (pos.8, fig.1a), located on the rare side of the carrier unit (pos.3, fig.1).
4. Consecutively mount to the back box of the button the following elements: the carrier unit, the breakable seal, the glass element with the sticker to cover and the cover.
5. Fix the protective cover to the back box by means of the breakable seal.

TESTING

Testing performance is individual for the specific application.

1. Testing – insert the spiral end of the test key into the opening (fig.3) and press to end. The glass element should fall. The button is activated.
2. Enabling – insert the flat end of the test key into the opening (fig.3) and press to end. The glass element should move to its initial position.

SERVICE SCHEDULE

1. Inspection for visible physical damage - weekly
2. Satisfactory operation test in real conditions -monthly

WARANTY

The warrant period is 36 months from the date of the purchase.

The manufacturer guarantees the normal operation of the fire detector providing that the service requirements of the instruction manual herein have been observed.

The manufacturer does not bear warranty liabilities for damages, caused through accidental mechanical, misuse, adaptation or modification after the production of the product.

The manufacturer bears warranty liabilities for damages in the manual call point caused through manufacturer's fault only.

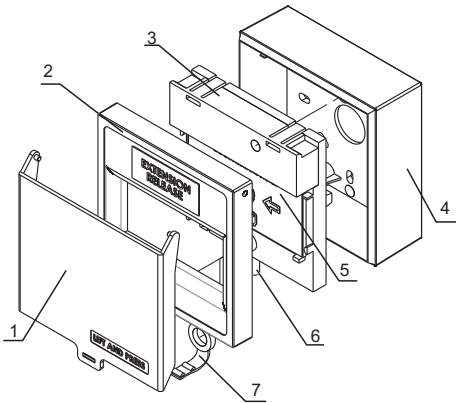

Fig.1

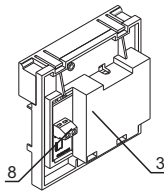

Fig.1a

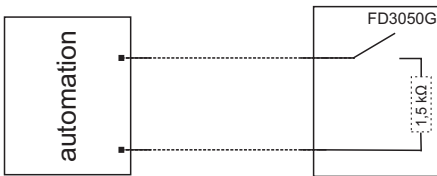

Fig.2

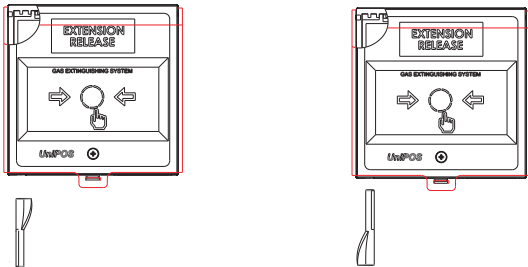

Fig.3